

**INSTALLATION, OPERATION AND
MAINTENANCE INSTRUCTIONS**

PACO INSTANT PUMPS

Submersible Non-Clog Pumps

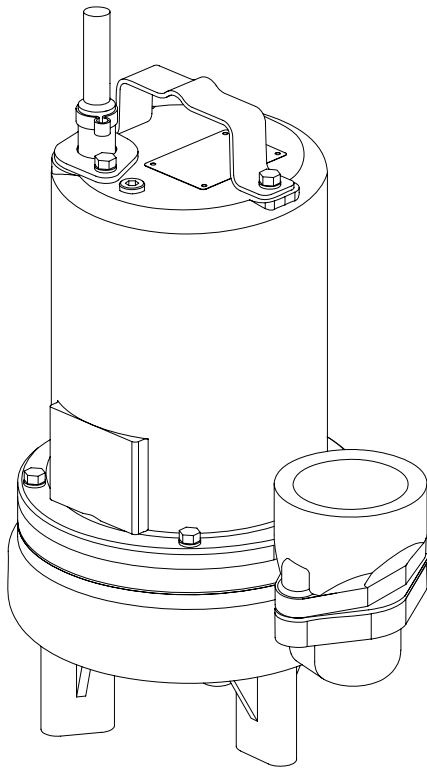

Series:

- PIP500B**
- PIP501B**
- PIP520B**
- PIP521B**
- PIP502B**
- PIP522B**
- PIP523B**
- PIP503B**
- PIP524B**
- PIP525B**

IMPORTANT!

*Read all instructions in this manual before operating pump.
As a result of constant product improvement program, product changes may occur.
As such Grundfos CBS, Inc. reserves the right to change product without prior
written notification.*

SAFETY FIRST!

Please Read This Before Installing Or Operating Pump. This information is provided for **SAFETY** and to **PREVENT EQUIPMENT PROBLEMS**. To help recognize this information, observe the following symbols:



IMPORTANT! Warns about hazards that can result in personal injury or indicates factors concerned with assembly, installation, operation, or maintenance which could result in damage to the machine or equipment if ignored.

CAUTION! Warns about hazards that **can or will cause minor** personal injury or property damage if ignored. Used with symbols below.

WARNING! Warns about hazards that can or will cause serious personal injury, death, or major property damage if ignored. Used with symbols below.



Hazardous fluids can cause fire or explosions, burns or death could result.



Extremely hot - Severe burns can occur on contact.



Biohazard can cause serious personal injury.



Hazardous fluids can cause hazardous pressure, eruptions or explosions could cause personal injury or property damage.



Rotating machinery Amputation or severe laceration can result.



Hazardous voltage can shock, burn or cause death.

Only qualified personnel should install, operate and repair pump. Any wiring of pumps should be performed by a qualified electrician.

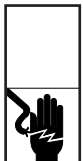

WARNING ! To reduce risk of electrical shock, pumps and control panels must be properly grounded in accordance with the National Electric Code (NEC) or the Canadian Electrical Code (CEC) and all applicable state, province, local codes and ordinances. Improper grounding voids warranty.



WARNING! To reduce risk of electrical shock, always disconnect the pump from the power source before handling or servicing. Lock out power and tag.



WARNING! Operation against a closed discharge valve will cause premature bearing and seal failure on any pump, and on end suction and self priming pump the heat build may cause the generation of steam with resulting dangerous pressures. It is recommended that a high case temperature switch or pressure relief valve be installed on the pump body.



CAUTION ! Never operate a pump with a plug-in type power cord without a ground fault circuit interrupter.



CAUTION ! Pumps build up heat and pressure during operation-allow time for pumps to cool before handling or servicing.



WARNING ! Do not pump hazardous materials (flammable, caustic, etc.) unless the pump is specifically designed and designated to handle them.



CAUTION ! Do not block or restrict discharge hose, as discharge hose may whip under pressure.



WARNING ! Do not wear loose clothing that may become entangled in moving parts.



WARNING ! Keep clear of suction and discharge openings. **DO NOT** insert fingers in pump with power connected.



Always wear eye protection when working on pumps.

Make sure lifting handles are securely fastened each time before lifting. **DO NOT** operate pump without safety devices in place. Always replace safety devices that have been removed during service or repair. Secure the pump in its operating position so it can not tip over, fall or slide.



DO NOT exceed manufacturers recommendation for maximum performance, as this could cause the motor to overheat.



DO NOT remove cord and strain relief. **DO NOT** connect conduit to pump.



WARNING ! Cable should be protected at all times to avoid punctures, cut, bruises and abrasions. Inspect frequently. Never handle connected power cords with wet hands.



WARNING ! To reduce risk of electrical shock, all wiring and junction connections should be made per the NEC or CEC and applicable state or province and local codes. Requirements may vary depending on usage and location.



WARNING! Submersible Pumps are not approved for use in swimming pools, recreational water installations decorative fountains or any installation where human contact with the pumped fluid is common.



WARNING! Products returned must be cleaned, sanitized, or decontaminated as necessary prior to shipment, to insure that employees will not be exposed to health hazards in handling said material. All Applicable Laws And Regulations Shall Apply.



Bronze/brass and bronze/brass fitted pumps may contain lead levels higher than considered safe for potable water systems. Lead is known to cause cancer and birth defects or other reproductive harm. Various government agencies have determined that leaded copper alloys should not be used in potable water applications. For non-leaded copper alloy materials of construction, please contact factory.



PACO® Pumps is not responsible for losses, injury, or death resulting from a failure to observe these safety precautions, misuse or abuse of pumps or equipment.

PUMP SPECIFICATIONS:

DISCHARGE 3" NPT, Female, Vertical
LIQUID TEMPERATURE 104°F (40°C) Continuous
VOLUTE Cast Iron ASTM A-48, Class 30
MOTOR HOUSING Cast Iron ASTM A-48, Class 30
SEAL PLATE Cast Iron ASTM A-48, Class 30
IMPELLER:
 Design 2 vane, Open with pump out vanes
 on back side. Balanced, ISO G6.3
 Material Cast Iron ASTM A-48, Class 30
SHAFT 416 Stainless Steel
O-RINGS Buna-N
HARDWARE 300 Series Stainless Steel
PAINT Air dry enamel
SEAL *Design* Single Mechanical
 Material Rotating Face - Carbon
 Stationary Face - Ceramic
 Elastomer - Buna-N
 Hardware - 300 series stainless steel

CORD ENTRY 15Ft. (4.5m) Cord. Plug on 120 Volt,
 Quick Connect, Custom Molded for
 sealing and strain relief
UPPER BEARING:
 Design Single Row, Ball, Oil Lubricated
 Load Radial
LOWER BEARING:
 Design Single Row, Ball, Oil Lubricated
 Load Radial & Thrust
MOTOR: *Design* NEMA L - Single Phase, NEMA B
 Three Phase Torque Curve. Oil Filled
 Squirrel Cage Induction
 Insulation Class B
SINGLE PHASE Permanent Split Capacitor (PSC)
 Includes Overload Protection in Motor
THREE PHASE Tri Voltage 200-240/480. Requires
 Overload Protection to be Included in
 Control Panel

MODEL NO	HP	VOLT/PH	Hz	RPM (Nom)	NEMA START CODE	FULL LOAD AMPS	LOCKED ROTOR AMPS	CORD SIZE	CORD TYPE	CORD SIZE	WINDING RESISTANCE		
											Emerson Main-Start	Franklin Main-Start	G.E. Main-Start
PIP500B	0.5	120/1	60	1750	F	11.6	21.3	14/3	SJTOW	0.375	----	----	1.51-16.1
PIP501B	0.5	240/1	60	1750	J	5.9	14.9	14/3	SOW	0.530	3.38-9.30	----	5.69-18.74
PIP520B	0.5	200-240/3	60	1750	H/L	3.2/3.0	9.8/11.0	14/4	SOW	0.570	10.2	13.0	----
PIP521B	0.5	480/3	60	1750	K	1.5	5.3	14/4	SOW	0.570	40.8	52.0	----
PIP502B	0.75	200-240/1	60	1750	G/K	7.4/7.0	21.5/25.8	14/3	SOW	0.530	1.86-10.2	----	2.74-10.56
PIP522B	0.75	200-240/3	60	1750	H/K	4.8/4.5	13.7/15.4	14/4	SOW	0.570	----	5.49	6.28
PIP523B	0.75	480/3	60	1750	K	2.2	7.7	14/4	SOW	0.570	----	21.96	24.51
PIP503B	1.0	200-240/1	60	1750	D/G	8.8/8.3	21.5/25.8	14/3	SOW	0.530	1.86-10.2	----	2.74-10.56
PIP524B	1.0	200-240/3	60	1750	E/H	5.14/4.9	13.7/15.4	14/4	SOW	0.570	----	5.49	6.28

Winding Resistance ± 5%.

Pump rated for operation at ± 10% voltage at motor.

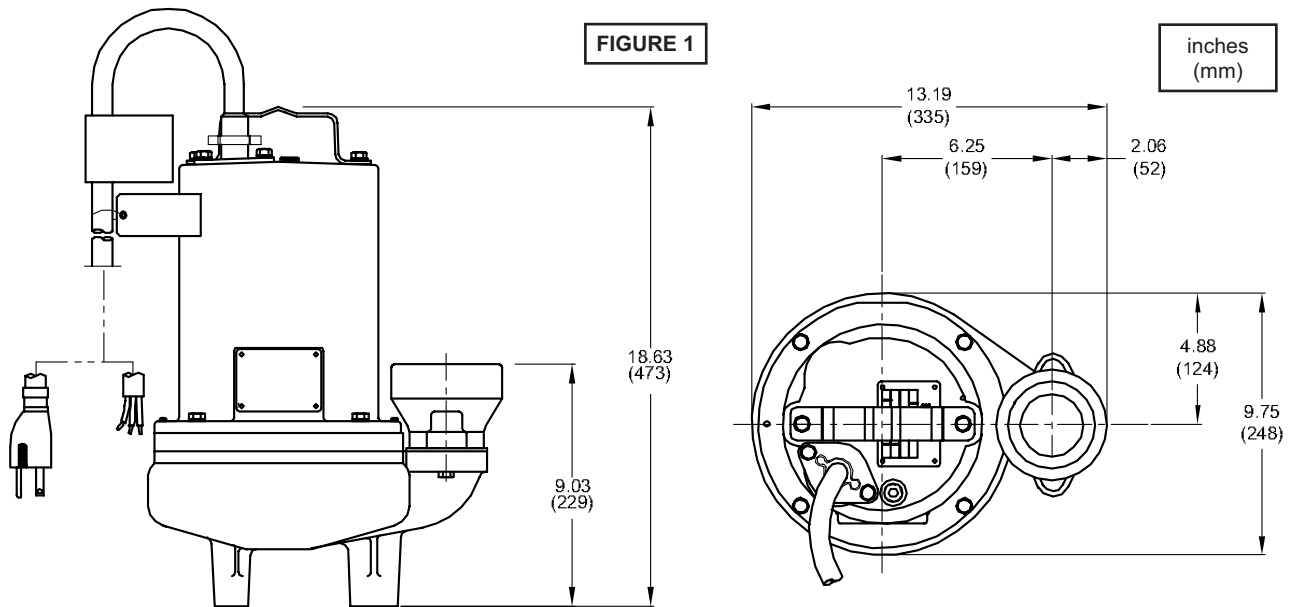

PUMP MODEL NO. _____

PUMP SERIAL NO. _____

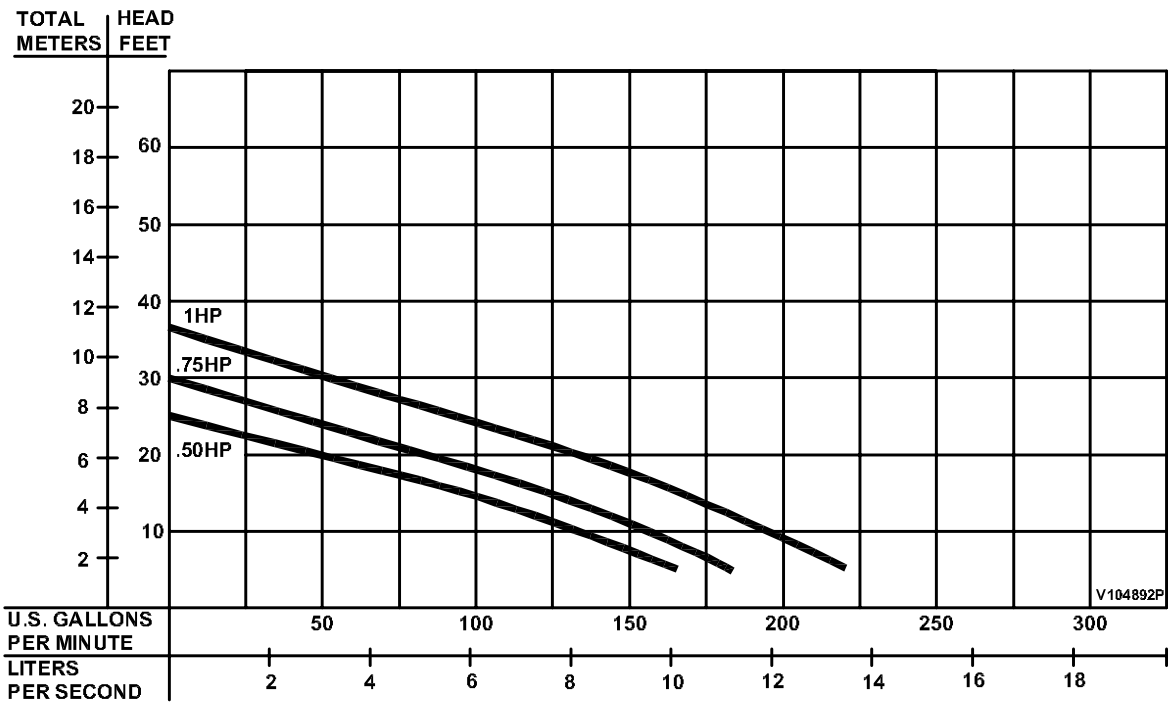

Testing is performed with water, specific gravity of 1.0 @ 68° F, other fluids may vary performance

SECTION B: GENERAL INFORMATION

B-1) To The Purchaser:

Your new Submersible Pump is constructed of the best available materials and is designed to give you many years of service with a minimum of attention.

This manual will provide helpful information concerning installation, maintenance, and proper service guidelines. Check local codes and requirements before installation. Servicing should be performed by knowledgeable pump service contractors or authorized service stations. The pump is packaged ready for installation and no connections or adjustments are necessary except for attaching discharge piping and connecting service cord.

B-2) Receiving:

Upon receiving the pump, it should be inspected for damage or shortages. If damage has occurred, file a claim immediately with the company that delivered the pump. If the manual is removed from the crating, **DO NOT** lose or misplace.

SECTION C: INSTALLATION

C-1) Location:

These pumping units are self-contained and are recommended for use in a sump, lift station or basin. The sump, lift station or basin shall be vented in accordance with local plumbing codes. **This pump is designed to pump sewage, effluent, or other nonexplosive or noncorrosive wastewater, and shall NOT be installed in locations classified as hazardous in accordance with the National Electrical Code (NEC), ANSI/NFPA 70 or the Canadian Electrical Code (CEC).**

Never install the pump in a trench, ditch or hole with a dirt bottom; the legs will sink into the dirt and the suction will become plugged.

C-1.1) Submergence:

It is recommended that the pump be operated in the submerged condition and the sump liquid level should never be less than 10 inches above the pump bottom (see Figure 2).

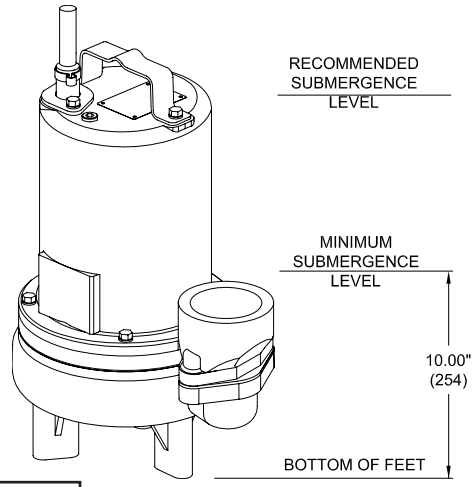

FIGURE 2

C-2) Discharge:

Discharge piping should be as short as possible. Both a check valve and a shut-off valve are recommended for each pump being used. The check valve is used to prevent backflow into the sump. Excessive backflow can cause flooding and/or damage to the pump. The shut-off valve is used to stop system flow during pump or check valve servicing.

C-3) Liquid Level Controls (Not Included with Pump):

The level controls are to be supported by a mounting bracket that is attached to the sump wall, cover or junction box. Be certain that the level controls cannot hang up or foul in it's swing and that the pump is completely submerged when the level control is in the "Off" mode.

Figure 3 shows a typical connection for 120 volt pumps with piggy-back plug and a wide angle float. For manual and automatic operations.

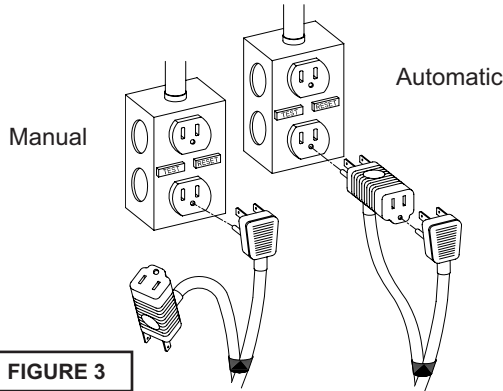

FIGURE 3

- Automatic - Plug float cord into outlet, then plug pump cord into float cord.
- Manual - Plug pump cord directly into outlet.

C-4) Electrical Connections:

An acceptable motor control switch shall be provided at the time of installation.

C-4.1) Power Cable:

The cord assembly mounted to the pump must not be modified in any way except for shortening to a specific application. Any splice between the pump and the control panel must be made in accordance with all applicable electric codes. It is recommended that a junction box, if used, be mounted outside the sump or be of at least Nema 4 (EEMAC-4) construction if located within the wet well. **Do not use the power cable to lift pump. NOTE: The white wire is NOT a neutral or ground lead, but a power carrying conductor.**

C-4.2) Overload Protection :

Single Phase - The type of in-winding overload protector used is referred to as an inherent overheating protector and operates on the combined effect of temperature and current. This means that the overload protector will trip out and shut the pump off if the windings become too hot, or the load current passing through them becomes too high. It will then automatically reset and start the pump up after the motor cools to a safe temperature.

In the event of an overload, the source of this condition should be determined and rectified immediately. **DO NOT LET THE PUMP CYCLE OR RUN IF AN OVERLOAD CONDITION OCCURS !**

If current through the temperature sensor exceeds the values listed, an intermediate control circuit relay must be used to reduce the current or the sensor will not work properly.

TEMPERATURE SENSOR ELECTRICAL RATINGS		
Volts	Continuous Amperes	Inrush Amperes
110-120	3.00	30.0
220-240	1.50	15.0
440-480	0.75	7.50

C-4.3) Wire Size:

Consult a qualified electrician for proper wire size if additional power cable length is required. See table on page 3 for electrical information.

SECTION: D START-UP OPERATION

D-1) Check Voltage and Phase:

Before operating pump, compare the voltage and phase information stamped on the pump's identification plate to the available power.

D-2) Check Pump Rotation:

Before putting pump into service for the first time, the motor rotation must be checked. Improper motor rotation can result in poor pump performance and can damage the motor and/or pump. To check the rotation, suspend the pump freely, momentarily apply power and observe the "kickback". "Kickback" should always be in a counter-clockwise direction as viewed from the top of the pump motor housing.

D-2.1) Incorrect Rotation for Three-Phase Pumps:

In the event that the rotation is incorrect for a three-phase installation, interchange any two power cable leads at the control box. **DO NOT** change leads in the cable housing in the motor. Recheck the "kickback" rotation again by momentarily applying power.

D-2.2) Incorrect Rotation for Single-Phase Pumps:

In the unlikely event that the rotation is incorrect for a single phase pump, contact a PACO PUMPS Service Center.

D-3) Identification Plate:

Record the numbers from the pump's identification plate for future reference.

D-4) Insulation Test:

Before the pump is put into service, an insulation (megger) test should be performed on the motor. The resistance values (ohms) as well as the voltage (volts) and current (amps) should be recorded.

D-5) Pump-Down Test:

After the pump has been properly wired and lowered into the basin, sump or lift station, it is advisable to check the system by filling with liquid and allowing the pump to operate through it's pumping cycle. The time needed to empty the system, or pump-down time along with the volume of water, should be recorded.

ECTION E: PREVENTATIVE MAINTENANCE

As the motor is oil filled, no lubrication or other maintenance is required, and generally will give very reliable service and can be expected to operate for years on normal sewage pumping without failing. However as with any mechanical piece of equipment a preventive maintenance program is recommended and suggested to include the following checks:

- 1) Inspect motor chamber for oil level and contamination and repair as required per section F-1.
- 2) Inspect impeller and body for excessive build-up or clogging and repair as required per section F-2.
- 3) Inspect motor and bearings and replace as required per section F-3.
- 4) Inspect seal for wear or leakage and repair as required per section F-4.

SECTION F: SERVICE AND REPAIR

NOTE: All item numbers in () refer to Figure 15.

F-1) Lubrication:

Anytime the pump is removed from operation, the cooling oil in the motor housing (5) should be checked visually for oil level and contamination.

F-1.1) Checking Oil:

Motor Housing- To check oil, set unit upright. Remove pipe plug (27) from housing (5). With a flashlight, visually inspect the oil in the motor housing (5) to make sure it is clean and clear, light amber in color and free from suspended particles. Milky white oil indicates the presence of water. Oil level should be just above the motor when pump is in vertical position.

F-1.2) Testing Oil:

- 1.) Place pump on it's side, remove pipe plug (27), from motor housing (5) and drain oil into a clean, dry container.
- 2.) Check oil for contamination using an oil tester with a range to 30 Kilovolts breakdown.
- 3.) If oil is found to be clean and uncontaminated (measuring above 15 KV. breakdown), refill the motor housing as per section F-1.4.
- 4.) If oil is found to be dirty or contaminated (or measures below 15 KV. breakdown), the the pump must be carefully inspected for leaks at the shaft seal (24), cable assembly (13), square ring (23) and pipe plug (27), before refilling with oil. To locate the leak, perform a pressure test as per section F-1.3. After leak is repaired, dispose of old oil properly, and refill with new oil as per section F-1.4.

F-1.3) Pressure Test:

Pumps that have been disassembled, Motor Housing:
If the pump has been disassembled, the oil should be drained before a pressure test, as described in section F-1.1. Remove pipe plug (27) from motor housing (5). Apply pipe sealant to pressure gauge assembly and tighten into hole (See Figure 4).

Pressurize motor housing to 10 P.S.I. Use soap solution around the sealed areas and inspect joints for "air bubbles". If, after five minutes, the pressure is still holding constant, and no "bubbles" are observed, slowly bleed the pressure and remove the gauge assembly. Replace oil as described in section F-1.4. If the pressure does not hold, then the leak must be located and repaired.

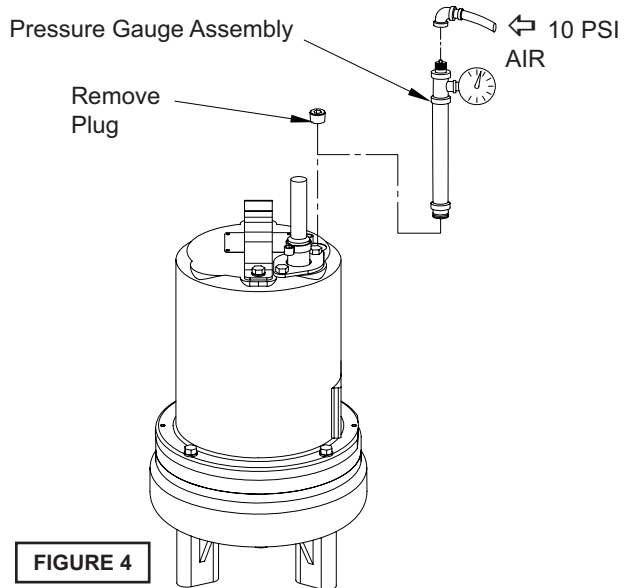

CAUTION ! - Pressure builds up extremely fast, increase pressure by "TAPPING" air nozzle. Too much pressure will damage seal. DO NOT exceed 10 P.S.I.

Pumps that have NOT been disassembled, Motor Housing:

The pressure test may be done with the oil at its normal level. Remove pipe plug (27) from motor housing (5). Apply pipe sealant to pressure gauge assembly and tighten into hole (see Figure 4). Pressurize motor housing to 10 P.S.I. Use soap solution around the sealed areas above the oil level and inspect joints for "air bubbles". For sealed areas below the oil level, leaks will seep oil.

If, after five minutes, the pressure is still holding constant, and no "bubbles"/oil seepage is observed, slowly bleed the pressure and remove the gauge assembly. If the pressure does not hold, then the leak must be located and repaired.

F-1.4) Replacing Oil:

Motor Housing - Set unit upright and refill with new cooling oil as per Table 1 (see parts list for amount). Fill to just above motor as an air space must remain in the top of the motor housing to compensate for oil expansion. Apply pipe thread compound to threads of pipe plug (27) then assemble to motor housing (5).



IMPORTANT! - For single phase units, oil level should be below capacitor.



WARNING ! - DO NOT overfill oil. Overfilling of motor housing with oil can create excessive and dangerous hydraulic pressure which can destroy the pump and create a hazard. Overfilling oil voids warranty.

TABLE 1 - COOLING OIL - Dielectric	
SUPPLIER	GRADE
BP	Enerpar SE100
Conoco	Pale Paraffin 22
Mobile	D.T.E. Oil Light
G & G Oil	Circulating 22
Imperial Oil	Voltesso-35
Shell Canada	Transformer-10
Texaco	Diala-Oil-AX
Woco	Premium 100

F-2) Impeller and Volute Service:

F-2.1) Disassembly and Inspection:

To clean out volute (1) or replace impeller (25), disconnect power, remove hex bolts (22), and lockwashers (11), vertically lift motor and seal plate assembly from volute (1) see Figure 5. Clean out body if necessary. Clean and examine impeller (25), for pitting or wear and replace if required, inspect gasket (26) and replace if cut or damaged. If the impeller (25) needs replacing, place a flat screwdriver in the slot of the end of the shaft to hold the shaft stationary while unscrewing the impeller (25).

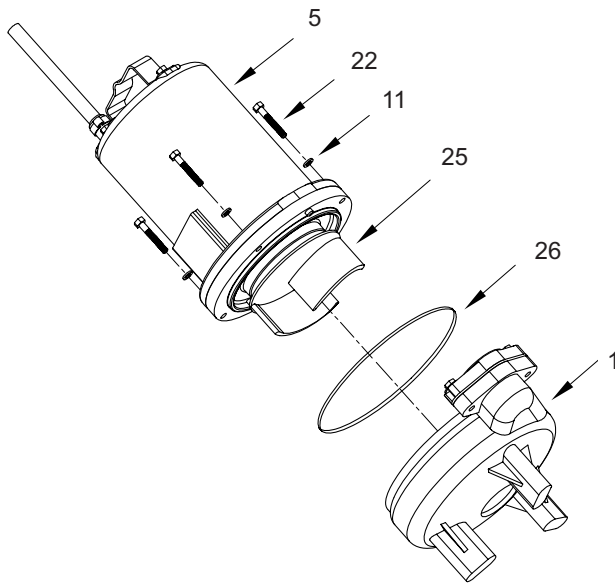

FIGURE 5

F-2.2) Reassembly:

To install impeller (25), clean the threads with thread locking compound cleaner. Apply removable Loctite® 609 or equivalent to shaft threads. Screw impeller onto the shaft hand tight while using a screwdriver in the slot at the end of the shaft to hold it stationary. It is important that the spring of the lower shaft seal (24) seats in the hub of the impeller (25). Rotate impeller to check for binding. Position gasket (26) on volute flange and position impeller and motor housing on volute (1). Position lockwasher (11) on cap screw (22) and screw into volute (1). Torque to 100 in-lbs. Check for free rotation of motor and impeller.

F-3) Shaft Seal Service:



CAUTION ! - handle seal parts with extreme care. DO NOT scratch or mar lapped surfaces.

F-3.1) Disassembly and Inspection:

To expose shaft seal (24) for examination, disassemble volute and impeller as outlined in paragraph F-2.1. If further repair is required, remove retaining ring (24d), spring (24c) and rotating member (24b) from shaft (see Figures 6 & 7). Examine all seal parts and especially contact faces. Inspect seal for signs of wear such as uneven wear pattern on stationary members, chips and scratches on either seal face. **DO NOT** interchange seal components, replace the entire shaft seal (24). If replacing seal, remove stationary (24a) by prying out with flat screwdriver.

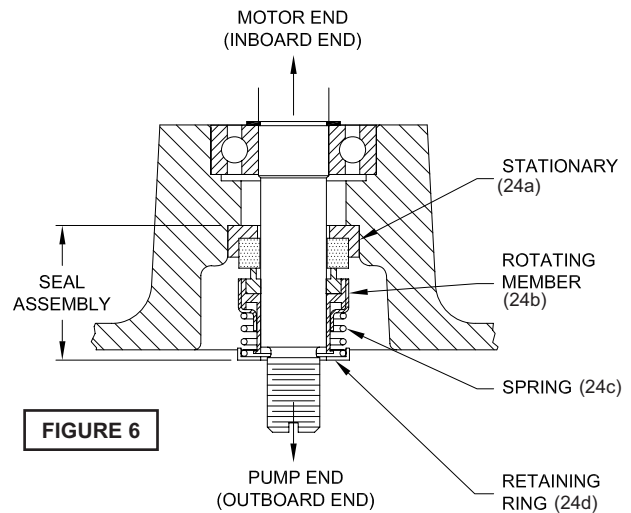

FIGURE 6

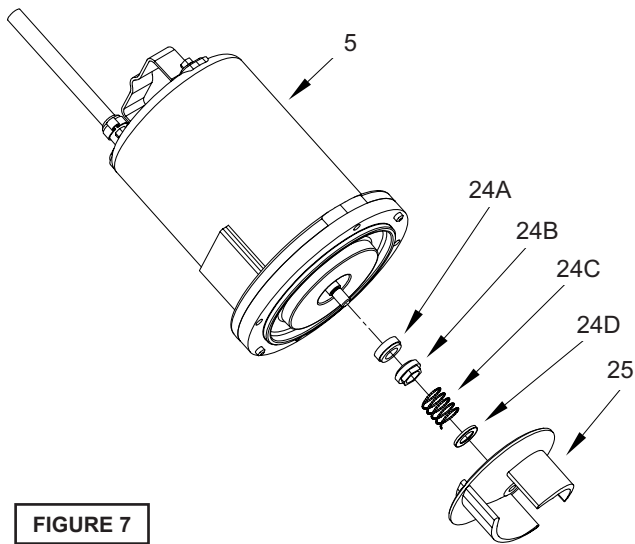

FIGURE 7

F-3.2) Reassembly:



IMPORTANT ! - DO NOT hammer on the seal pusher- it will damage the seal face.

Clean and oil seal cavities in seal plate (4). Lightly oil (**DO NOT use grease**) outer surface of stationary member (24a). Press stationary member (24a) firmly into seal plate (4), using a seal pusher. Nothing but the seal pusher is to come in contact with seal face (see Figure 8). Make sure the stationary member is in straight. Slide a bullet over motor shaft.

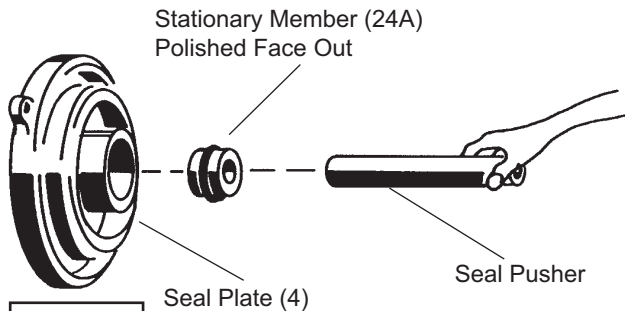

FIGURE 8

Lightly oil (**DO NOT use grease**) shaft, bullet and inner surface of bellows on rotating member (24b) see Figure 9. With lapped surface of rotating member (24b) facing inward toward stationary member, slide rotating member over bullet and onto shaft, using seal pusher, until lapped faces of (24a) and (24b) are together (see Figure 6).

It is extremely important to keep seal faces clean during assembly. Dirt particles lodged between these faces will cause the seal to leak. Place spring (24c) over shaft and in place on rotating member (24b), making sure it is seated on retainer and not cocked or resting on bellows tail. Slide retaining ring (24d) over shaft and let rest on spring (24c). Place spring (24c) and retaining ring (24d) onto rotating member (24b). Assemble impeller and volute as outlined in paragraph F-2.2. Replace oil as outlined in paragraph F-1.4.

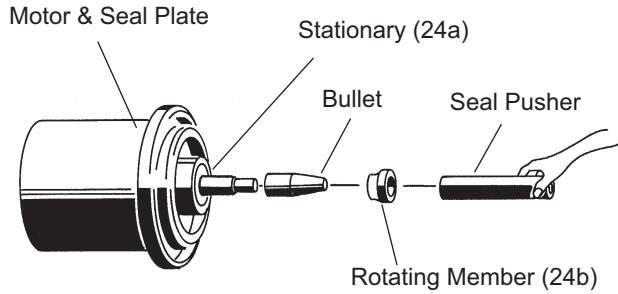

FIGURE 9

F-4) Motor and Bearing Service

F-4.1) Disassembly and Inspection:

To examine or replace the motor (6), capacitor (8, single phase units), and bearing (21), drain oil from motor as outlined in paragraph F-1.1. Disassemble volute and impeller as outlined in paragraph F-2.1 and disassemble shaft seal as outlined in paragraph F-3.1.

Position unit upright, using blocks to avoid resting unit on shaft. Unscrew cable hex bolts (10) and remove compression flange (14) and power cord (13). Remove snap ring (15) with a flat head screwdriver. Pull the terminal block (17) out of the housing (5) using a T-bolt or pair of pliers and a .25-20 screw in the threads of the terminal block (17). Be sure to leave slack on the motor leads connected underneath (see Figure 10). Use needle nose pliers to pull each female connector off of the pins on the underside of the terminal block (17) see Figure 12. The unit voltage should be noted. Remove socket head cap screws (32). Vertically lift the motor housing (5) from seal plate (4) by lifting handle (12). Inspect square ring (23) for damage or cuts. Remove the motor bolts and lift motor stator from seal plate (4). Disconnect capacitor leads from capacitor (8, single phase units). Examine bearing (21) and replace if required. If replacement is required, remove bearing (21) from motor shaft using a wheel puller or arbor press, see Figure 11.

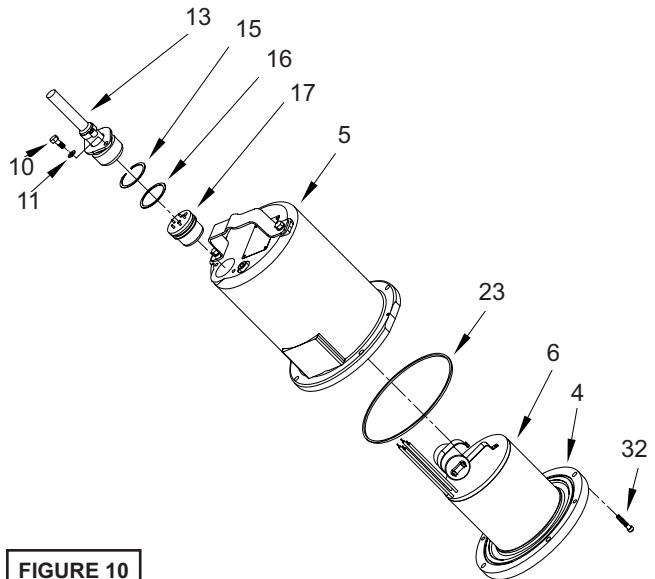

FIGURE 10

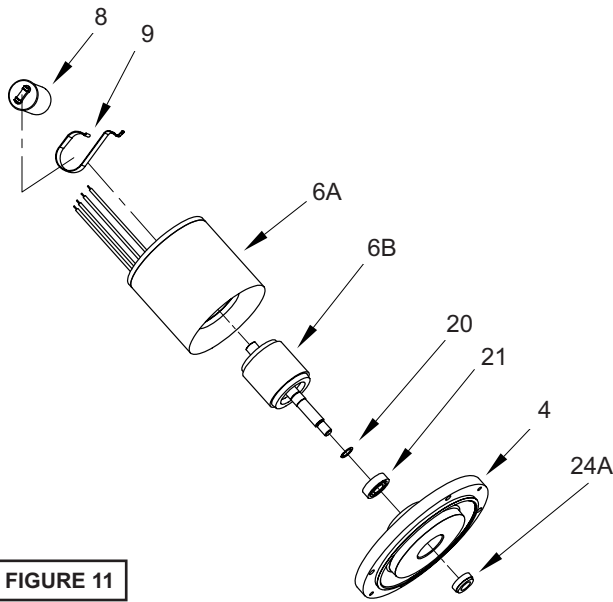

FIGURE 11

Check motor capacitor (8, single phase units) with an Ohm meter by first grounding the capacitor by placing a screwdriver across both terminals and then removing screwdriver. Connect Ohm meter (set on high scale) to terminals. If needle moves to infinity (∞) then drifts back, the capacitor is good. If needle does not move or moves to infinity (∞) and does not drift back, replace capacitor (8).

Inspect motor winding for shorts and check resistance values. Check rotor for wear. If rotor or the stator windings are defective, the complete motor must be replaced.



IMPORTANT! - all parts must be clean before reassembly.

F-4.2) Reassembly:

Bearings - When replacing bearing, be careful not to damage the rotor or shaft threads. Clean the shaft thoroughly. Press bearing (21) on the motor shaft, position squarely onto the shaft applying force to the inner race of the bearing only, until bearing seats against the retaining ring (20).

Motor - Slide lower bearing (21) and motor shaft squarely into the seal plate (4) until bearing seats on the bottom. Place stator over rotor, lining up motor bolts with holes in seal plate (4). Position capacitor (8, single phase units) so that it will lay on the opposite side of the cable entry boss of the motor housing (5). Reconnect capacitor leads. Torque motor tie bolts to 17 in-lbs. Set square ring (23) in grove on seal plate (4).

F-4.3) Wiring Connections:

Check power cable (13) for cracks or damage and replace if required (see Figure 12). Make internal wiring connections which are independent of the terminal block as shown, using connectors (36) as required. **Do not use wire nuts.** Slip motor leads and ground wire through fiberglass sleeve.

Lower motor housing (5) down onto seal plate (4) while aligning holes and stringing motor leads through the cord entry bore. (Slipping cord inside a 1 ft. length of .5" conduit makes this easier). Place socket head cap screws (32) through seal plate (4) into motor housing (5) and torque to 60 in-lbs. Reconnect motor and leads to the underside of the terminal block (17), as shown in Figures 12 & 13. Note that the pins are numbered underneath the terminal block. Place o-ring (16) into groove in terminal block and lubricate with dielectric oil. Press the terminal block (17) into the housing so it seats completely below the snap ring groove. Place snap ring (15) into groove in cord entry bore of housing.

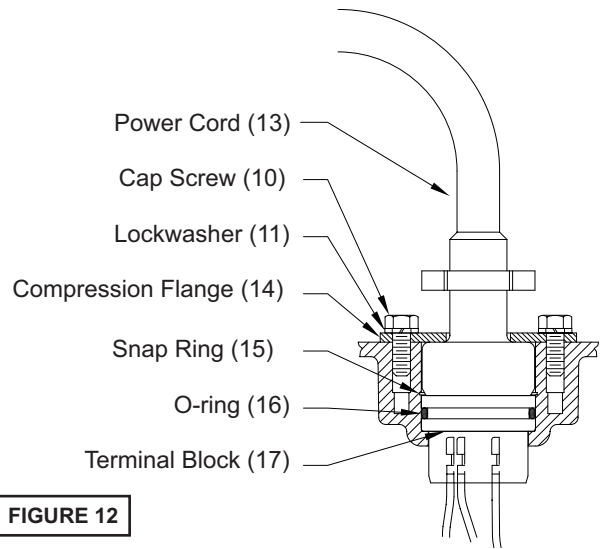

FIGURE 12

F-4.4) Cord Assemblies:

Power Cord - Refill the cooling oil as outlined in paragraph F-1.3. Make wire connections as outlined in paragraph F-4.3. Insert female end of cord plug into housing bore aligning timing mark with hole in terminal block (17) see Figure 14. Compress cord plug with compression flange (14) by tightening hex bolts (10) into the housing (5). Torque to 132 in-lbs.

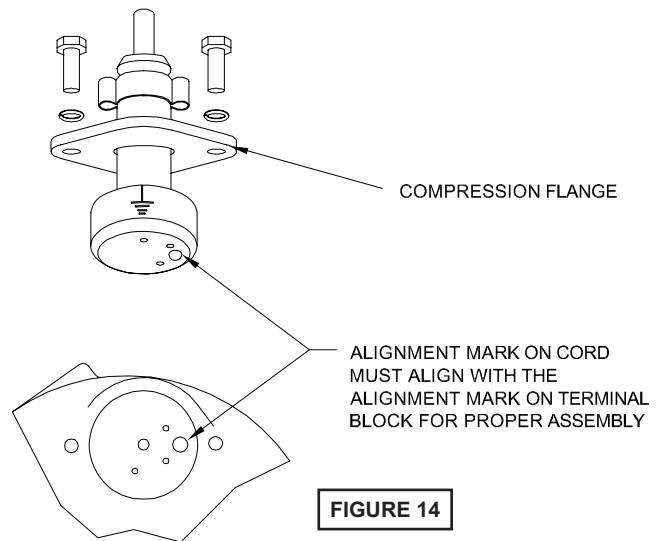

FIGURE 14

SECTION: G REPLACEMENT PARTS

G-1) Ordering Replacement Parts:

When ordering replacement parts, ALWAYS furnish the

1. Pump serial number and date code,
2. Pump model number,
3. Pump Component number.

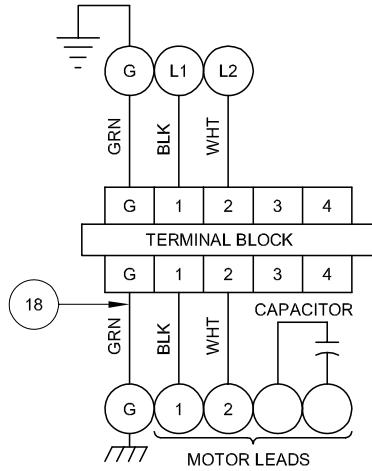

**STANDARD TEMPERATURE
SINGLE PHASE - 120/240 VOLT AC (PSC)**

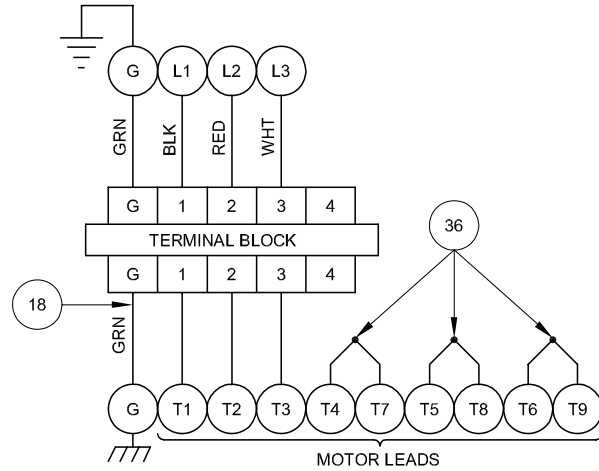

THREE PHASE - 480 VOLT AC

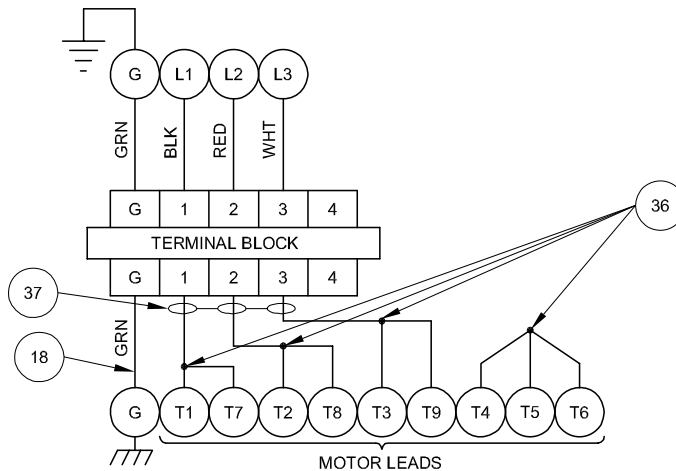

THREE PHASE - 200/240 VOLT AC

FIGURE 13

TROUBLE SHOOTING

CAUTION ! Always disconnect the pump from the electrical power source before handling.
If the system fails to operate properly, carefully read instructions and perform maintenance recommendations.
If operating problems persist, the following chart may be of assistance in identifying and correcting them:

MATCH "CAUSE" NUMBER WITH CORRELATING "CORRECTION" NUMBER.

NOTE: Not all problems and corrections will apply to each pump model.

PROBLEM	CAUSE	CORRECTION
Pump will not run	<ol style="list-style-type: none"> 1. Poor electrical connection, blown fuse, tripped breaker or other interruption of power, improper power supply. 2. Motor or switch inoperative (to isolate cause, go to manual operation of pump). 2a. Float movement restricted. 2b. Switch will not activate pump or is defective. 3. Insufficient liquid level. 	<ol style="list-style-type: none"> 1. Check all electrical connections for security. Have electrician measure current in motor leads, if current is within $\pm 20\%$ of locked rotor Amps, impeller is probably locked. If current is 0, overload may be tripped. Remove power, allow pump to cool, then recheck current. 2a. Reposition pump or clean basin as required to provide adequate clearance for float. 2b. Disconnect level control. Set ohmmeter for a low range, such as 100 ohms full scale and connect to level control leads. Actuate level control manually and check to see that ohmmeter shows zero ohms for closed switch and full scale for open switch. (Float Switch). 3. Make sure liquid level is at least equal to suggested turn-on point.
Pump will not turn off	<ol style="list-style-type: none"> 2a. Float movement restricted. 2b. Switch will not activate pump or is defective. 4. Excessive inflow or pump not properly sized for application. 9. Pump may be airlocked. 14. H-O-A switch on panel is in "HAND" position 	<ol style="list-style-type: none"> 4. Recheck all sizing calculations to determine proper pump size. 5. Check discharge line for restrictions, including ice if line passes through or into cold areas. 6. Remove and examine check valve for proper installation and freedom of operation. 7. Open valve. 8. Check cutter for freedom of operation, security and condition. Clean cutter and inlet of any obstruction. 9. Loosen union slightly to allow trapped air to escape. Verify that turn-off level of switch is set so that the suction is always flooded. Clean vent hole.
Pump hums but does not run	<ol style="list-style-type: none"> 1. Incorrect voltage 8. Cutter jammed or loose on shaft, worn or damaged, inlet plugged. 	<ol style="list-style-type: none"> 4. Recheck all sizing calculations to determine proper pump size. 5. Check discharge line for restrictions, including ice if line passes through or into cold areas.
Pump delivers insufficient capacity	<ol style="list-style-type: none"> 1. Incorrect voltage. 4. Excessive inflow or pump not properly sized for application. 5. Discharge restricted. 6. Check valve stuck closed or installed backwards. 7. Shut-off valve closed. 8. Cutter jammed or loose on shaft, worn or damaged, inlet plugged. 9. Pump may be airlocked. 10. Pump stator damaged/torn. 	<ol style="list-style-type: none"> 6. Remove and examine check valve for proper installation and freedom of operation. 7. Open valve. 8. Check cutter for freedom of operation, security and condition. Clean cutter and inlet of any obstruction. 9. Loosen union slightly to allow trapped air to escape. Verify that turn-off level of switch is set so that the suction is always flooded. Clean vent hole. 10. Remove & examine for damage. Replace pump stator if required. 11. Repair fixtures as required to eliminate leakage.
Pump cycles too frequently or runs periodically when fixtures are not in use	<ol style="list-style-type: none"> 6. Check valve stuck closed or installed backwards. 11. Fixtures are leaking. 15. Ground water entering basin. 	<ol style="list-style-type: none"> 10. Remove & examine for damage. Replace pump stator if required. 11. Repair fixtures as required to eliminate leakage. 12. Check pump temperature limits & fluid temperature. 13. Replace portion of discharge pipe with flexible connector. 14. Turn to automatic position. 15. Check for leaks around basin inlet and outlets.
Pump shuts off and turns on independent of switch, (trips thermal overload protector). CAUTION! Pump may start unexpectedly. Disconnect power supply.	<ol style="list-style-type: none"> 1. Incorrect voltage. 4. Excessive inflow or pump not properly sized for application. 8. Cutter jammed, loose on shaft, worn or damaged, inlet plugged. 12. Excessive water temperature. 	<ol style="list-style-type: none"> 12. Check pump temperature limits & fluid temperature. 13. Replace portion of discharge pipe with flexible connector. 14. Turn to automatic position. 15. Check for leaks around basin inlet and outlets.
Pump operates noisily or vibrates excessively	<ol style="list-style-type: none"> 4. Operating at too high a pressure. 5. Discharge restricted. 8. Cutter broken. 13. Piping attachments to building structure too rigid or too loose. 	

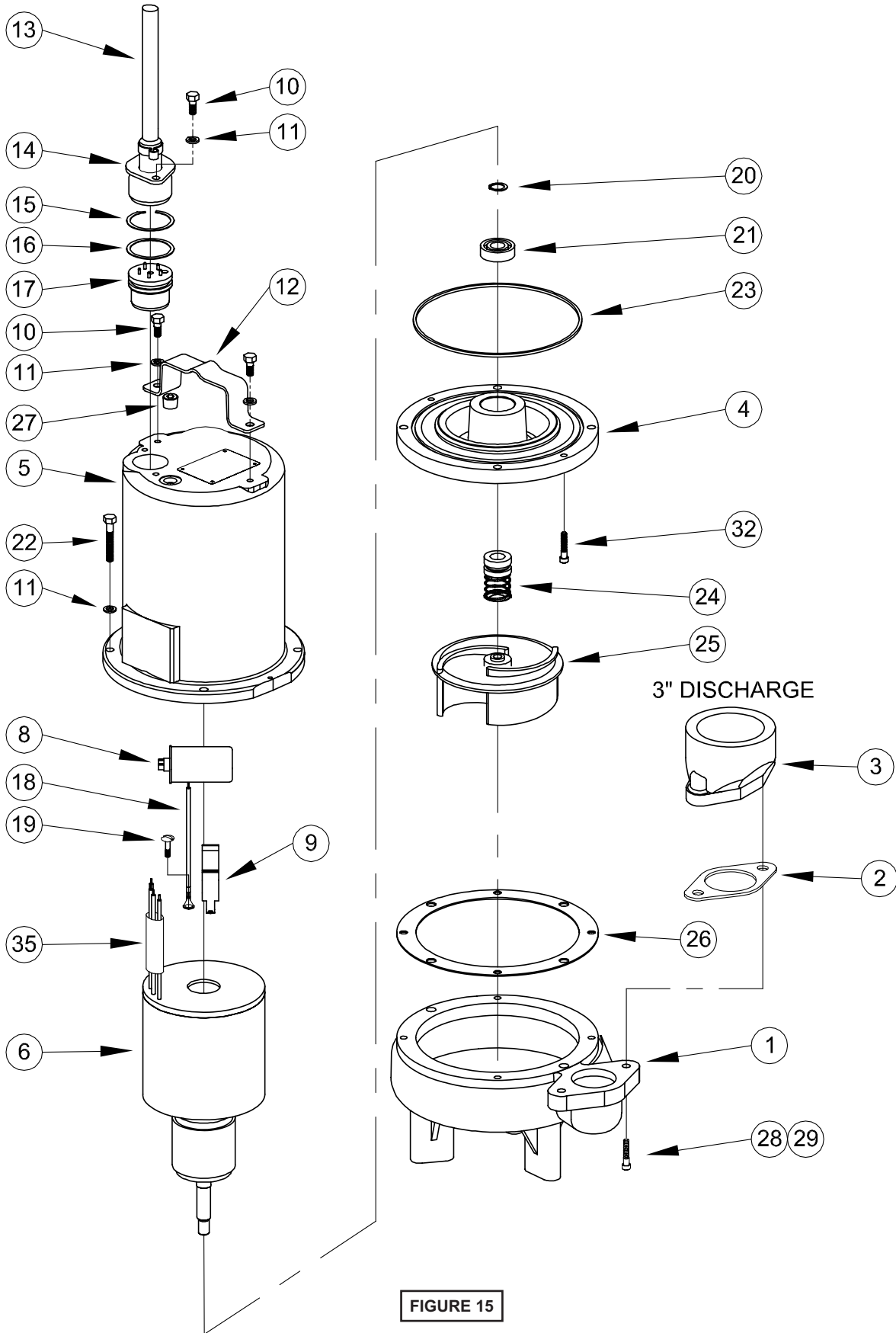

FIGURE 15

PARTS KITS

Seal Repair Kit.....P/N: 107272 (Item #'s 2, 23, 24, 26)

Overhaul Kit.....P/N: 111521 (Item #'s 2, 15, 16, 20, 21, 24, 26, 27, 35, 37)

PARTS LIST

ITEM	QTY.	PART NO.	DESCRIPTION
1	1	055400	Volute (Std)
2	1	069140	Gasket
3	1	074498	Flange 3" Discharge
4	1	084532	Seal Plate
5	1	105196	Motor Housing
6	1	Motor:	Capacitor (item 8):
		030369BS	034964 PIP500B
		030370BS	070963 PIP501B
		071352BS	None PIP520B, PIP521B
		029792BS	070963 PIP502B, PIP503B
		071354BS	None PIP522B, PIP523B, PIP524B, PIP525B
7	96 oz	029034	Oil
8	1	034964	Capacitor (30MFD) 1 Phase
	1	070963	Capacitor (20MFD) 1 Phase
9	1	039858	Capacitor Bracket 1 Phase
10	4	1-156-1	Hex. Hd. Cap Screw, 5/16-18 x 1.00" Lg., Stainless
11	8	026322	Lockwasher, 5/16, Stainless
12	1	103503	Handle
13	1	103756	Power Cable Set 120 Volt, 1 Phase
		110949	240 Volt, 1 Phase .5Hp
		103741	240 Volt, 1 Phase .75 & 1Hp
		103742	3 Phase
14	1	103582	Compression Flange (Included with Cable Set)
15	1	105197	Snap Ring
16	1	2-31051-224	O-ring
17	1	103584	Terminal Block, 1 Phase
		103583	Terminal Block, 3 Phase
18	1	105111	Ground Wire Assembly
19	1	016660	Screw, Self Tapping #8-32 x .375" Lg.
20	1	085326	Retaining Ring
21	1	017414	Bearing
22	4	1-135-1	Cap Screw, 5/16-18 x 1.75" Lg., Stainless
23	1	027269	Square Ring
24	1	005080	Shaft Seal - Carbon/Ceramic/Buna-N (STD)
25	1	084346	Impeller, Cast Iron, 6.00 Dia. (STD for 1 HP)
		084346TC	5.63 Dia. (STD for .75 HP)
		084346TF	5.25 Dia. (STD for .5 HP)
26	1	027344	Gasket
27	1	014270	Pipe Plug .375" NPT
28	2	1-131-1	Hex. Hd. Cap Screw, 5/16-18 x 1.25" Lg., Stainless
29	A/R	----	Loctite 242
30	A/R	----	Permatex 2C
32	2	084948	Socket Head Cap Screw 1/4-20 x 1.25" Lg., Stainless
34	A/R	----	Loctite 609
35	1	625-02117	Sleeve, Fiberglass
36	4	105150	Terminal Connector 200-240V, 3Ph
	3	625-00163	Terminal Connector 480V, 3PH
37	3	105149	Wire Assembly 200-240V, 3Ph

D4d.1c
4/06
Supersedes 7/05

PACO®
PUMPS

Check our worldwide offices at
www.paco-pumps.com